

Inground Trampoline

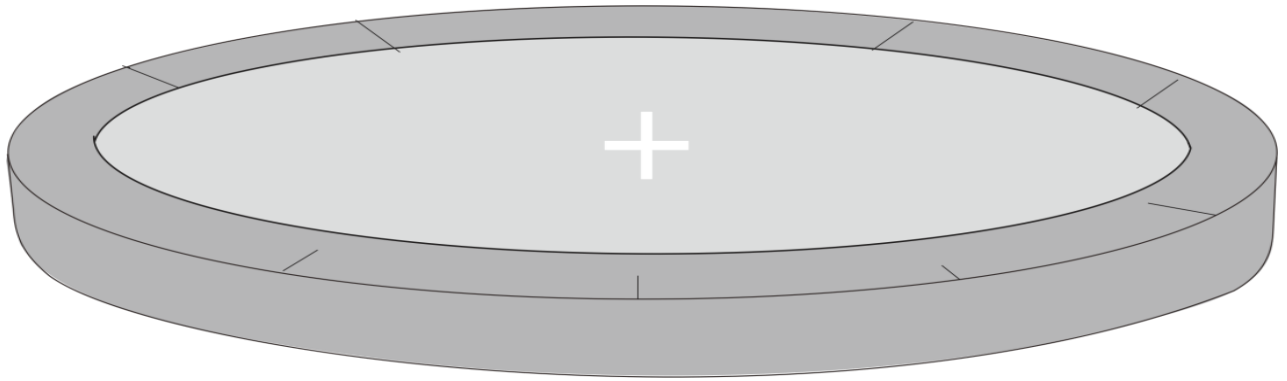

- 8'(244 cm) Trampoline**
- 10'(305 cm) Trampoline**
- 12'(366 cm) Trampoline**
- 13'(396 cm) Trampoline**
- 14'(427 cm) Trampoline**

- 3 Legs*
- 4 Legs*

Spring : 48 54 72 80 88

Assembly, Installation, Care, Maintenance and Use Instructions

Manual depicts typical installation - your model may differ from illustrations

READ THIS FIRST!!!

Thank you for purchasing our product

**IN CASE OF MISSING OR BROKEN
PARTS, PLEASE CONTACT PLACE OF
PURCHASE FOR ASSISTANCE.**

ADDITIONAL INFORMATION

Like any activity that puts your body in motion, trampolining carries with it certain risks. To decrease the risk of injury. We recommend the use of an enclosure to prevent users falling off the trampoline. The enclosure should not be used to intentionally bounce off the sides. No device can completely guarantee your safety and safe play remains your responsibility, an enclosure substantially reduces the risk of injury. Never allow more than one person on the trampoline at a time. Do not attempt inverts, flips or somersaults. We also suggest use of an impact absorbing surface on the ground around the trampoline.

BOUNCE SAFELY ON YOUR TRAMPOLINE



Misuse and abuse of this trampoline is dangerous and can cause serious injury or death

1. **DO NOT** attempt or allow somersaults. Landing on the head or neck can cause serious injury, paralysis, or death, even when landing in the middle of the mat.
2. **DO not** allow more than one person on the trampoline at any one time. Use by more than one person at the same time can result in serious injuries.
3. Use the trampoline only with mature, adult knowledgeable supervision.
4. Trampolines over 20 in.(51cm) tall are not recommended for use by children under 6 years of age.
5. Inspect the trampoline before each use. Make sure the frame Pad is correctly and securely positioned. Replace any worn, defective, or missing parts.
6. Climb on and off the trampoline. Do not jump from the trampoline to the floor or ground when dismounting, or onto the trampoline when mounting. **Do not** use the trampoline as a springboard to other objects.
7. Stop bounce by flexing knees as feet come in contact with the trampoline mat. Learn this skill before attempting others.
8. Learn fundamental bounces and body positions thoroughly before trying more advanced maneuvers. A variety of trampoline maneuvers can be carried out by performing the basic fundamentals in different combinations, performing one fundamental after another, with or without feet bounces between them. **Refer to the Bouncing Basic section in this manual.**

BOUNCE SAFELY ON YOUR TRAMPOLINE

9. Avoid bouncing too high. Stay low until bounce control and repeated landing in the center of the trampoline has been achieved. Control is more important than height.
10. While bouncing, keep head up and facing forward with eyes focused on the perimeter of the trampoline. This will help control balance.
11. Do not bounce when tired or for prolonged periods.
12. Secure the trampoline correctly when not in use and prevent unauthorized use. If a trampoline ladder is used, remove it from the trampoline when leaving the area to prevent unsupervised access by children under 6 years of age.
13. Maintain a clear area around the trampoline and remove objects which could obstruct the user.
14. **Do not** use the trampoline while under the influence of alcohol or drugs.
15. For information about skills & training, contact a certified trampoline instructor.
16. Bounce only when the mat is dry. The trampoline must not be used in windy conditions.
17. Read all instructions before using the trampoline. Warnings and instructions for the care, maintenance, and use of this trampoline are included to promote safe, enjoyable use of this equipment.
 - **DO NOT** wear hard-soled shoes as they cause excessive wear to the mat.
 - **DO NOT** wear jewelry, hooks, buttons, or other protrusions that might get caught on the mat.
 - Bounce in center of the mat.

INSTALLATION

1. Ensure adequate overhead clearance. A minimum of 26 feet (8 meters) from ground level is recommended. Provide clearance for wires, tree branches, and other possible hazards.
2. Ensure adequate lateral clearance. Place the trampoline away from walls, structures, fences, swimming pools, and other play areas. Maintain a clear space on all sides of the trampoline.
3. Place the trampoline on a level surface before use.
4. Use the trampoline in a well-lighted area. Artificial illumination may be required for shady areas.
5. Secure the trampoline in a safe place.
6. Remove any obstructions from beneath the trampoline.
7. The owner and supervisors of the trampoline are responsible to making all users aware of practices specified in the instructions.

INTRODUCTION

Before using this trampoline, please read all information

provided in this manual carefully. To reduce the risk of injury, please follow appropriate safety rules and tips.

- ※ Misuse and abuse of this trampoline is dangerous and can result in serious injury!
- ※ Inspect the trampoline before each use for wear and tear, loose or missing parts.
- ※ Assembly, care and maintenance of product, safety tips, warnings, and proper techniques in jumping and bouncing are all included in this manual.
- ※ All users and supervisors must read and familiarize themselves with these instructions.
- ※ All users must be aware of their own limitations when performing jumps and bounces with this trampoline.
- ※ For family domestic use only.
- ※ The safety net shall be equipped if the length/diameter/diagonals of the frame greater than 2.5m

warning

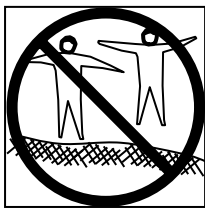

NO MORE THAN ONE
PERSON AT A TIME ON THE
TRAMPOLINE!
MULTIPLE JUMPERS
INCREASE THE RISK OF
INJURY SUCH AS BROKEN
NECK, LEG, BACK OR
HEAD INJURY



DO NOT PERFORM
SOMERSAULTS (FLIPS) AS
THIS WILL INCREASE RISK OF
LANDING ON HEAD OR NECK
RESULTING IN INCREASED
RISK OF SERIOUS INJURY OR
DEATH

Always consult a physician before performing any kind of physical activity

PLEASE RETAIN THIS INFORMATION FOR FUTURE REFERENCE

INFORMATION ON USE OF THE TRAMPOLINE

Initially, get accustomed to the feel and bounce of the trampoline. The focus must be on the fundamentals of your body position and you should practice each bounce (the basic bounces) until you can perform each with ease and control.

To brake a bounce, flex your knees sharply before your feet come in contact with the mat.

This technique should be practiced as you are learning each of the basic bounces.

The skill of braking should be used whenever you lose balance or control of your jump.

Always learn the simplest bounce first and be consistent with the control of your bounce before moving on to more difficult and advanced bounces. **A controlled bounce is when your take off point and landing point is the same spot on the mat.** If you move up to the next bounce without first mastering the previous, you increase your risk of injury.

Do not bounce on the trampoline for extended periods of time as fatigue can increase your risk of injury. Bounce only for a brief period of time. Only one person should bounce on the trampoline at a time.

Jumpers should wear a t-shirt, shorts or sweats, and regulation gymnastics shoes, heavy socks, or be barefoot. If you are just beginning, you may want to wear long sleeve shirts and pants to protect against scrapes and abrasions until you master correct landing positions and form. Do not wear hard sole shoes, such as tennis shoes, on the trampoline as this will cause excessive wear on the mat.

You should always mount and dismount properly in order to avoid injury. To mount properly, you should place your hand on the frame and step or roll up onto the frame, over the springs, and onto the trampoline mat. Always remember to place your hands onto the frame while mounting or dismounting. Do not step directly onto the frame pad or grasp the frame pad. To dismount properly, move to the side of the trampoline and place your hand onto the frame as a support and step from the mat to the ground. Smaller children should be assisted when mounting and dismounting.

Do not bounce recklessly on the trampoline as this will increase your risk of injury. The key to safety and having fun on the trampoline is control and mastering the various bounces. Never try to out-bounce another bouncer in terms of height! Never use the trampoline without supervision.

ACCIDENT CLASSIFICATION

Mounting and Dismounting: Be very careful when getting on and off the trampoline. **DO NOT** mount the trampoline by grabbing the frame pad, by stepping onto the springs, or by jumping onto the mat from any surface (e.g. a deck, roof, or ladder) as this will increase your risk of injury. **DO NOT** dismount by jumping off the trampoline. If small children are playing on the trampoline, they may need help in mounting and dismounting.

Use of Alcohol or Drugs: **DO NOT** consume any alcohol or drugs before or while using this trampoline as this will impair your judgement, reaction time, and overall physical coordination.

Multiple Jumpers: If you have multiple jumpers (more than one person on the trampoline at any one time), you increase the chance of getting injured. Injuries could occur when you fly off the trampoline, lose control, collide with the other jumper(s), or land on the springs. Generally, the lightest person on the trampoline will get injured.

Striking the Frame or Springs: When playing on the trampoline, STAY in the center of the mat. This will reduce your risk of injury from the frame or springs. Always keep the frame pad on the frame DO NOT jump or step onto the frame pad, it is not intended to support the weight of a person.

Loss of Control: DO NOT try difficult manoeuvres until you have mastered the Previous maneuver as this will increase your risk of injury. A controlled jump is when your take off Point and landing point is the same spot on the mat. If you lose control when you are jumping on the Trampoline, bend your knees sharply when you land and this will allow you to stop your jump and regain Control.

Somersaults (Flips): DO NOT PERFORM somersaults of any type (backwards or forwards) on this Trampoline as this will increase your risk of injury to your neck or back, which may Result in death or paralysis.

Foreign Objects: DO NOT use the trampoline if there are pets, other people, animals or any objects beneath, above or near the trampoline as this will increase the risk of an injury occurring. DO NOT hold any foreign objects in your hand and DO NOT place any objects on the trampoline. Please be aware of what is overhead when you are using the trampoline. Tree branches, wires, or other objects located above the trampoline may result in injury.

Poor Maintenance of Trampoline: A trampoline in poor condition will increase your risk of injury. Please inspect the trampoline before each use for bent steel tubes, torn mat, loose or broken springs and overall stability of the trampoline.

Weather Conditions: Please be aware of the weather conditions when using the trampoline. Do not use trampoline if the mat is wet. Do not use the trampoline in windy conditions.

Limiting Access: When the trampoline is not in use, always store the access ladder in a secure place to prevent unauthorized and unsupervised access.

TIPS TO REDUCE THE RISK OF ACCIDENTS

Jumper's role in accident prevention

Stay in control of your jumps. DO NOT move onto more complicated, or more difficult manoeuvres until you have mastered the basic, fundamental bounce.

Education is key to safety. Read, understand, and practice all safety precautions and warnings prior to using the trampoline. A controlled jump is when you land and take off from the same point on the mat. For additional safety tips and instructions, contact a certified trampoline

instructor.

- Always bounce at the centre of the bed. Bouncing near the edge of the bed can lead to injury and can also stretch the springs. The frame pad is not designed nor intended to support the weight of the trampoline user. Do not step or jump directly onto the frame pad.
- Avoid bouncing too high. Stay low until you can control your bounce and land consistently in the middle of the bed.
- To regain control and stop your jump, bend your knees quickly when you land.
- Do not use the trampoline when under the influence of alcohol or drugs.
- Allow each jumper a brief turn on the trampoline. Extended bouncing exposes an over tired user to an increased risk of injury. Longer turns tend to lessen the interest of others waiting to jump.
- The trampoline mat is several feet from the ground. Jumping off the trampoline to the ground or any other surface may result in injury. Jumping onto the trampoline from a roof, deck, or other object also represents a risk of injury. Smaller children may need assistance getting up on or down from the trampoline. Mounting and dismounting properly should be a strict rule from the very beginning. Users should climb onto the trampoline by placing their hands on the frame and stepping or rolling up onto the frame, across the springs, and onto the mat (bed). Do not step directly on the frame pad or grasp the frame pad when mounting or dismounting the trampoline. Users should always place their hands on the frame while mounting or dismounting. To dismount, jumpers should walk to the side of the mat (bed), bend over and place one hand on the frame, then step from the mat to the ground.
- Injury may result from hitting the frame or falling through the springs while jumping or getting on or off the trampoline. Stay in the centre of the trampoline mat when jumping. **BE SURE TO KEEP THE FRAME PAD IN PLACE TO COVER THE FRAME AT ALL TIMES.** The frame pad is not designed nor intended to support the weight of the trampoline user. Do not step or jump directly onto the frame pad.

Supervisor's Role in Accident Prevention

Supervisors must understand and enforce all safety rules and guidelines. It is the responsibility of the supervisor to provide knowledgeable advice and guidance to all jumpers. If supervision is unavailable or inadequate, the trampoline should be disassembled and stored in a secure place to prevent unauthorized use. The supervisor is also responsible to ensure that the safety placard is placed on the trampoline and that jumpers are informed of these warnings and instructions.

TRAMPOLINE SAFETY INSTRUCTIONS

JUMPERS:

- ※ Do not use trampoline while under the influence of alcohol or any drugs.

-
- ※Remove all hard sharp objects from your person before using trampoline.
 - ※Climb on and off in a controlled and careful manner. Do not jump on or off the trampoline and never use the trampoline as a device to bounce onto or into another object.
 - ※Learn the basic bounce and master each type of bounce before trying more difficult types bounces. Review the Basic Skills Section to learn how the basics.
 - ※To stop your bounce, flex your knees as feet come in contact with mat.
 - ※Always be in control when you are bouncing on the trampoline. A controlled jump is when you land at the same point you took off from. If at any time you feel out of control, stop.
 - ※Do not jump or bounce for prolonged periods of time.
 - ※Keep your eyes on the mat to maintain control. If you do not, you could lose balance or control
 - ※Never more than 1 person on the trampoline at any time
 - ※ Always use trampoline under adult supervision.
 - ※ Adults must assemble this trampoline.
 - ※ No modification should be carried out to the trampoline or any of its components. Any modification could lead to damage to the product or to personal injury.

SUPERVISORS

Educate yourself about the basic jumps and safety rules. Enforce all safety rules and ensure that new jumpers learn the basic bounces before trying more difficult and advanced jumps.

- ※All jumpers need to be supervised, regardless of skill level or age.
- ※Never use the trampoline when it is wet, damaged, dirty, or worn. The trampoline should be inspected before any jumpers start bouncing on it.
- ※Keep all objects that could obstruct the jumper away from the trampoline. Be aware of what is overhead, underneath, and around the trampoline.
- ※Prevent unsupervised and unauthorized use. Trampoline should be secured when not in use.

TRAMPOLINE PLACEMENT

The minimum overhead clearance required is 26 feet (8 meters). Ensure that no hazards or obstructions are near the trampoline such as tree branches, swing sets, swimming pools, electrical power wires, walls, fences, etc.

Please be aware of the following when selecting a place for your trampoline:

- ※ Trampoline must be placed on a level surface
- ※ The area must be well-lit.
- ※ All obstructions from overhead, underneath or around the trampoline must be removed.
- ※ Do not use this trampoline in-door
- ※ Do not use this trampoline on any slippery floor surface, uneven or sloping ground surface
- ※ Do not site trampoline on hard surfaces ,concrete etc ,as this can damage the frame
- ※ The trampoline must be well-fix on the ground to prevent moving when jumping.

You increase the risk of someone getting injured if you do not follow these guidelines.

WARNING!

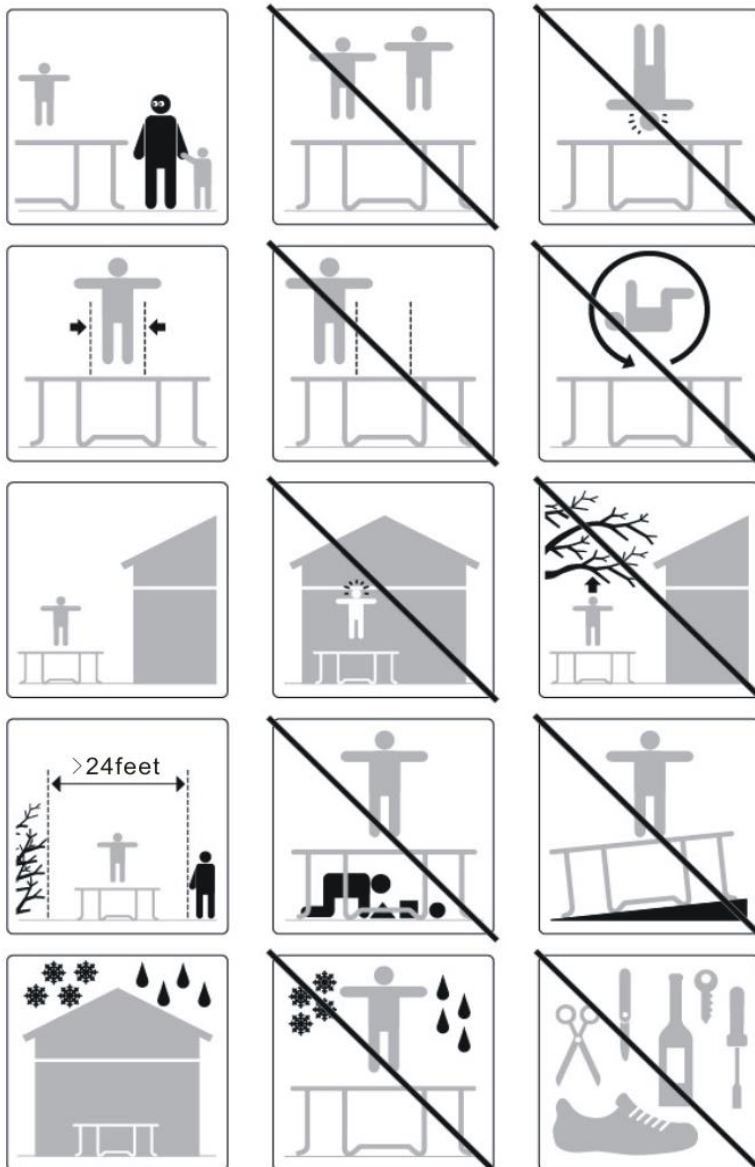

LESSON PLAN

The following lessons are recommended in order to learn basic steps and bounces before moving onto more difficult, complicated bounces. You should read and understand all safety instructions before mounting the trampoline. A complete discussion and demonstration of body mechanics and trampoline guidelines should occur between the supervisor and student.

Lesson 1

- A. Mounting and Dismounting - Demonstration of proper techniques
- B. The Basic Bounce-Demonstration and practice
- C. Braking (Check the Bounce) - Demonstration and practice. Learn to brake on command
- D. Hands and knees - Demonstration and practice. Stress should be on four- point landing and alignment

Lesson 2

- A. Review and practice of techniques learned in Lesson 1
- B. Knee Bounce-Demonstration and practice. Learn the basic down to knee and back up before trying half twist to left and right
- C. Seat Bounce -Demonstration and practice. Learn basic seat bounce then add a knee bounce, hands and knees; repeat

Lesson 3

- A. Review and practice skills and techniques learned in previous lessons
- B. Front Drop-All students should be requested to assume the prone position(face down on the ground) while the instructor checks for faulty positions that could cause injury
- C. Start with a hands and knees bounce and then extend body into prone position, land on the mat and return to feet
- D. Practice Routine-Hands and knees Bounce, Front Bounce, back to feet, seat bounce, back to feet

Lesson 4

- A. Review and practice skills and techniques learned in previous lessons
- B. Half-Turn
 - i. Start from front drop position. As you make contact with the mat, push off with arms in either the right or left direction and turn head and shoulders in same direction.
 - ii. During turn, be sure to keep back parallel to mat and head up.
 - iii After completing turn, land in front drop position

After completing this lesson, the student now has a basic understanding of trampoline bounces. Jumpers should be encouraged to develop their own routines with emphasis on control and form.

A game that can be played in order to encourage students to try and develop routines is "BOUNCE". In this game, players count off from 1 to 10. Player one starts with a manoeuver. Player two has to do Player One's manoeuver and add on another. Player Three does the manoeuvres of One and Two and then adds a third manoeuver. This continues until a player cannot do the routine properly in the correct sequence. The first person to miss, receives the letter "B". **This** continues until someone spells out the word "BOUNCE". The last remaining contestant is deemed the winner! Even when playing this game, it is important to **perform your routines under control**. Do not try difficult or highly skilled bounces which you have not yet mastered.

A certified trampoline instructor should be contacted to further develop your trampoline skills.

BASIC TRAMPOLINE BOUNCES

THE BASIC BOUNCE

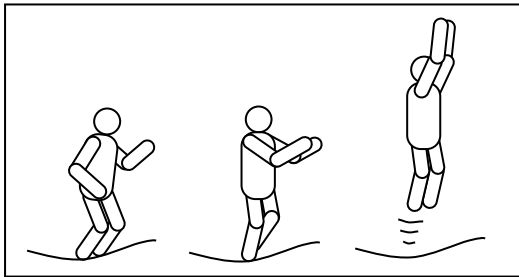

1. Start from standing position, feet should be width apart and head up and eyes on mat
2. Swing arms forward, up and around in a circular motion.
3. Bring feet together while in mid-air and point toes downward
4. Keep feet shoulder width apart when landing on mat.

KNEE BOUNCE

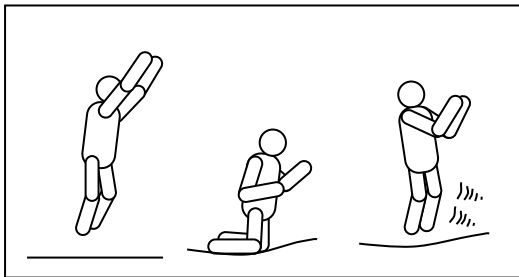

1. Start with basic bounce and keep it low
2. Land on knees keeping back straight, body erect. Use arms to maintain balance.
3. Bounce back to basic bounce position by swinging arms up

SEAT BOUNCE

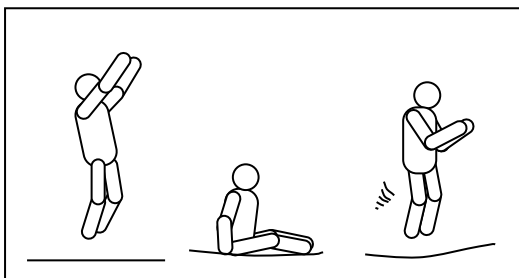

1. Land in a flat sitting position.
2. Place hands on mat besides hips
3. Return to erect position by pushing with hands.

FRONT BOUNCE

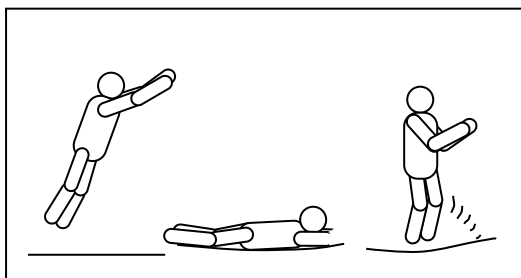

1. Start with a low bounce
2. Land in prone (face down) position and keep hand and arms extended forward on mat
3. Push off the mat with arms to return to standing position

180 DEGREE BOUNCE

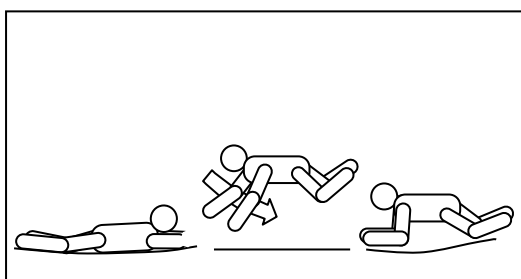

1. Start with front bounce position
2. Push off with left or right hands and arms (depending on which way you wish to turn)
3. Maintain head and shoulders in the same direction and keep back parallel to mat and head up
4. Land in prone position and return to standing position by pushing up with hands and arms

ASSEMBLY INSTRUCTIONS

- Only assemble by adult.

To assemble this trampoline all you need is our special spring loading tool provided with this product. During periods of non-use. This trampoline can be easily disassembled and stored.

Please read the assembly instructions before beginning to assemble the product.

PRIOR TO ASSEMBLING

Please refer to the table for part descriptions and numbers. The assembly instruction use these descriptions and numbers as reference.

Make sure you have all parts listed. If you are missing any parts, please contact place of purchase.

Please use gloves to protect your hands from pinch points during assembly.

PARTS LIST

Please select your trampoline size.

OTHER ITEMS – Trampolines have six legs

Reference Number	Part Number	Description	8'	10'	12'	13'	14'
1	TR800	Trampoline Mat, stitched with V-Rings	1	1	1	1	1
2	TR801	Frame Pad	1	1	1	1	1
3	TR802	Top Rail	6	6	8	8	8
4	TR803	Leg Base	3	3	4	4	4
5	TR804	Leg Base	3	3	4	4	4
6	TR805	Screw	12	12	12	12	12
7	TR806	T shape section	6	6	8	8	8
8	TR807	Clip with spring tool	1	1	1	1	1
9	TR808	Ground Anchor	1	1	1	1	1
10	TR809	Measuring Scale	1	1	1	1	1

Enclosed are the current specifications and product features available at time of printing, however, changes may be made in equipment, availability, specifications and features without notice.

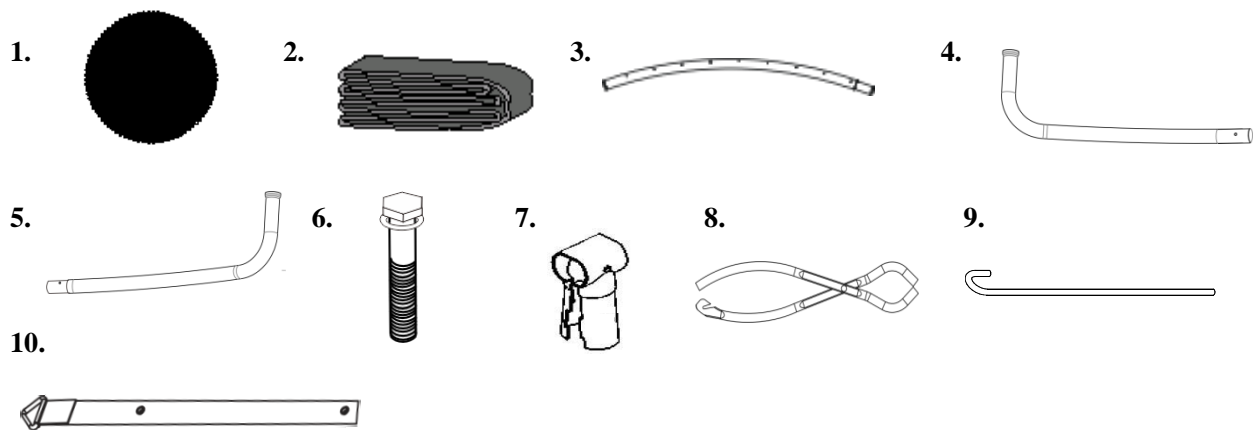

TWO PEOPLE ARE REQUIRED TO ASSEMBLE THE TRAMPOLINE, REMEMBER TO USE GLOVES DURING ASSEMBLY TO AVOID PINCHING

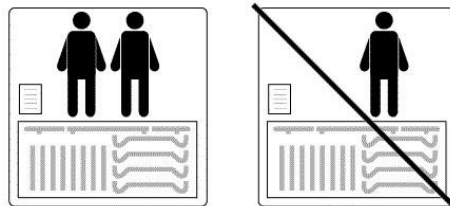

STEP 1 – Frame Layout

Check that you have received all parts using the relevant illustrations below. All parts with the same part # are interchangeable and do not have “right” or “left” orientation,

To connect the parts, simply slide a section of tubing into the adjacent section. These joints are called “T shape section”

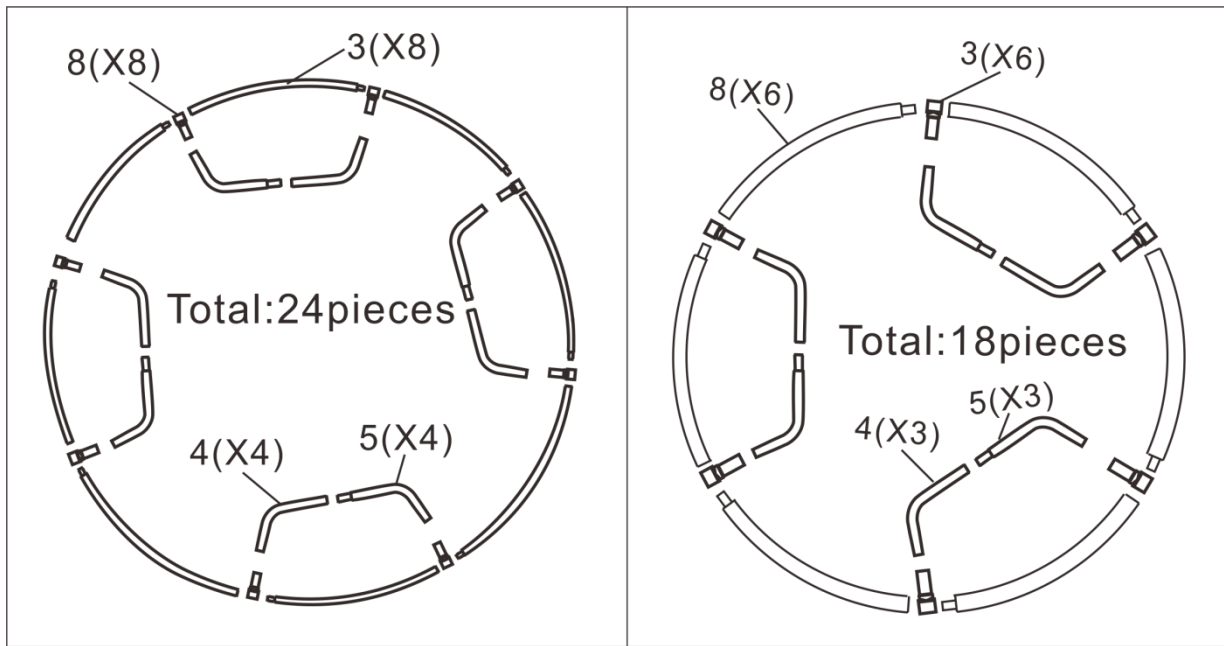

STEP 2 - Support Assembly

Connected Leg Base 4 and Leg Base 5 with screw 6

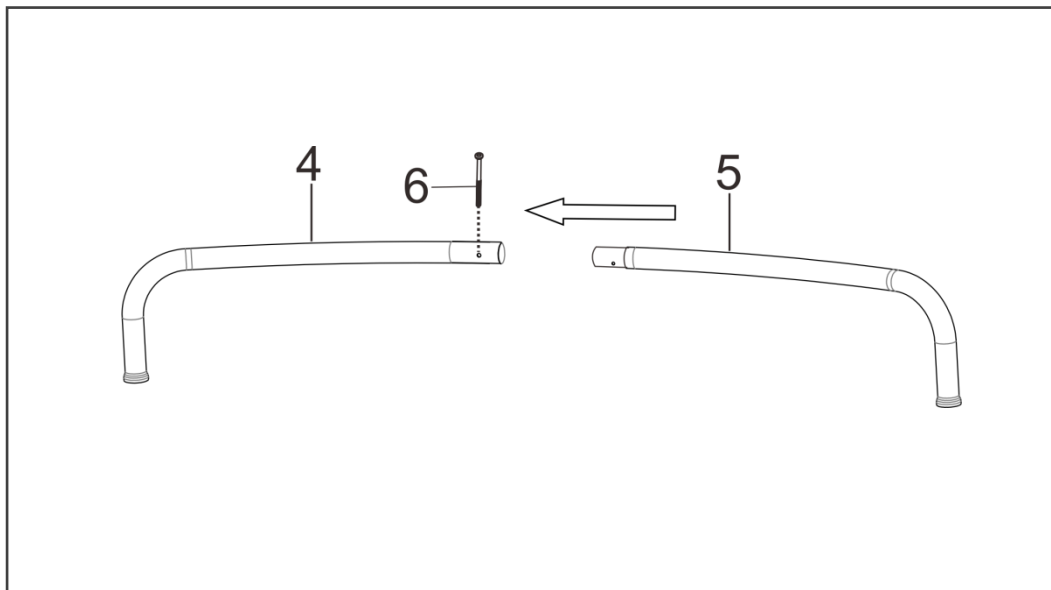

STEP 2 - Support Assembly

1. Insert T-section (7) into one end of top rail (3). Ensure the hole in the T-section matches the hole in the rail. Use a rubber mallet if necessary. Use the spring hook tool to help you to spread the T-section if necessary. Repeat for the other T-sections, but do not connect the top rail sections together yet.

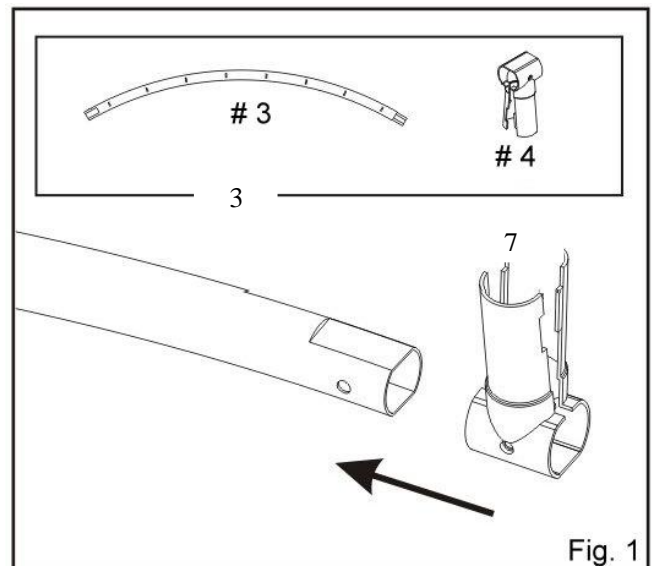

Fig. 1

2. Fit the leg tubes (3) onto the T-sections using the spring hook tool to compress the T-section. Note that the orientation of the leg tubes is important (The dilation part need to fit the T-sections) .**The T-sections must be fitted to the wider end of the leg tubes.** Take care not to pinch your fingers when compressing the T-sections.

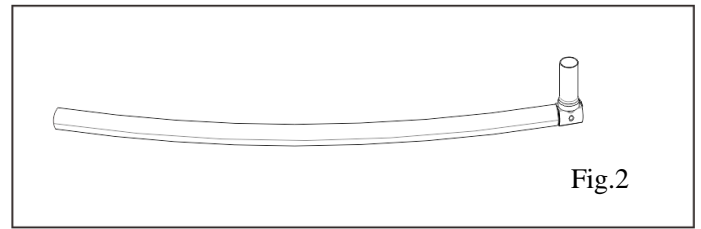

Fig.2

Note that the orientation of the leg tubes is important .The dilation part need to fit the T-sections. The T-sections must be fitted to the wider end of the leg tubes.

3. Connect 4 top rail sections together. Repeat for the other top rail sections as shown in Fig 3

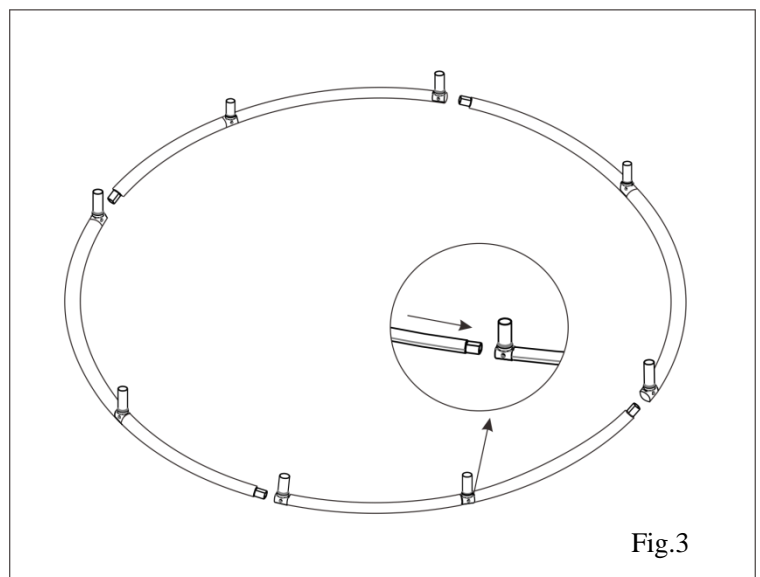

Fig.3

4. Fit the Connected Leg Base 4 and Leg Base 5 onto the two T shape sections(7) at the Top Rail(3) using the Clip of the spring tool(8) to help as shown in Fig 4. Make sure all into place.

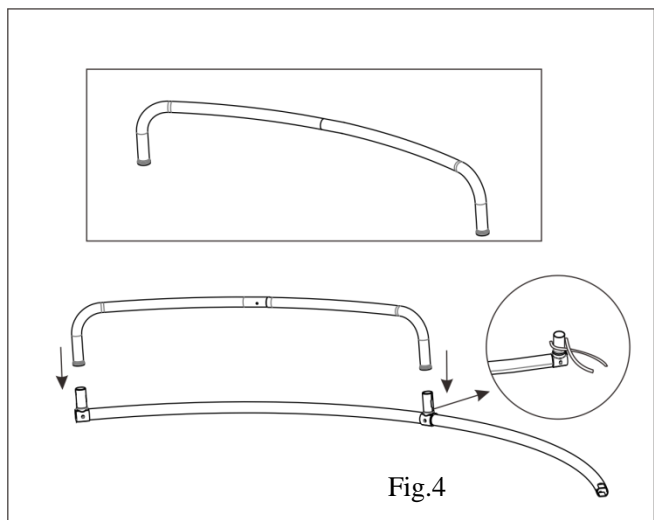
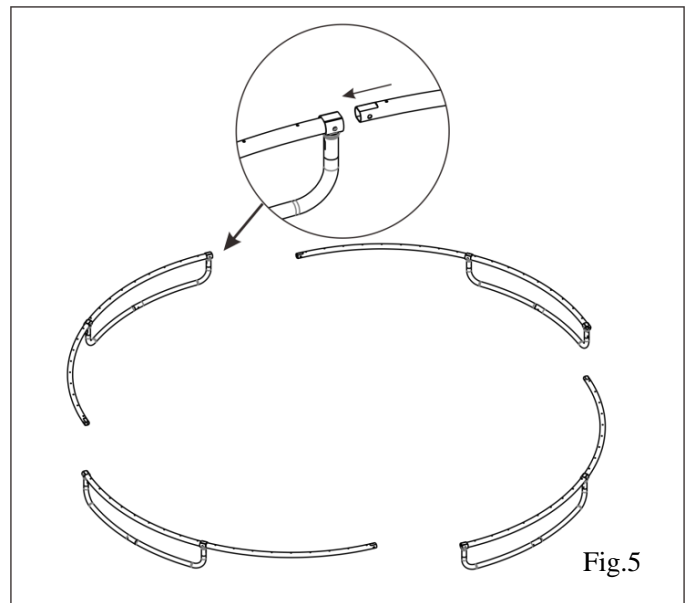
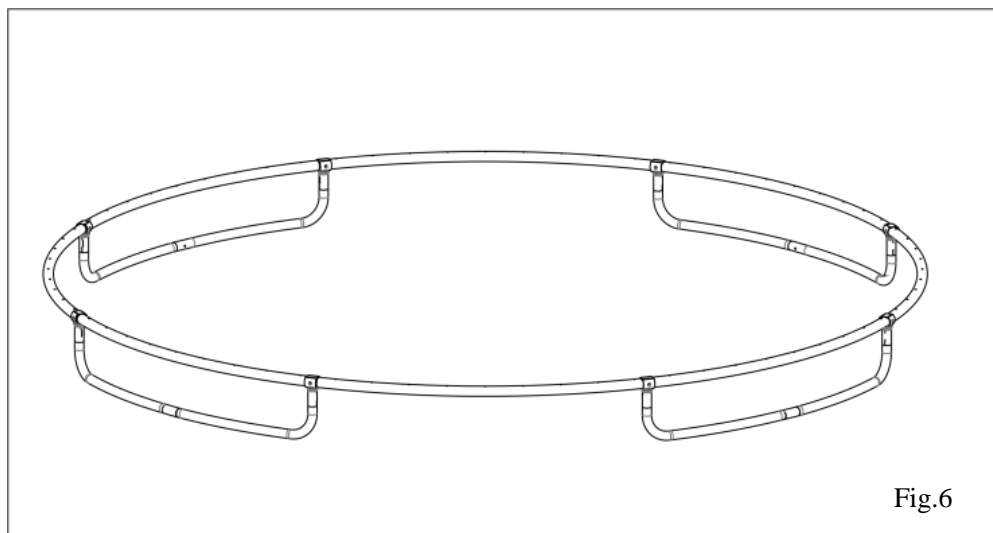

Fig.4

5. Connect the remaining tubes as shown in Fig.5



6. The completed framework should be the same as fig.6.



⚠ WARNING ⚠

IMPORTANT - It is essential that the intended site for this trampoline is completely flat and level. If the ground is un-level this will cause movement in the frame and could cause stress on the joined sections.

STEP 3 - Trampoline Mat Assembly

Take care when attaching springs to the trampoline mat. You will need another person to help you with this part of the assembly. ATTENTION-When attaching the Springs, the Connector Points can pinch as the trampoline is tightening up.

A. Lay out the Trampoline Mat(1) inside the frame

The white cross and safety labels should be facing upwards

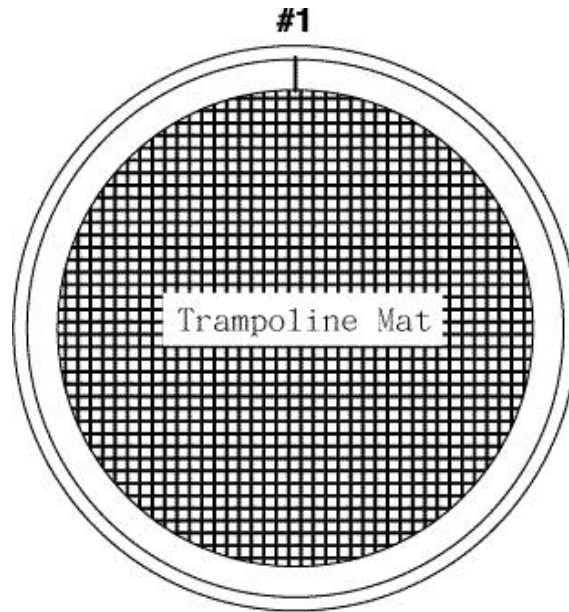

B. How to use the spring tool.

STEP 1: Position the spring on the edge of jumping mat (Select your Spring type A or B). Attach tool and link up to the spring hook with hook end of the tool.

STEP 2: Pull the tool and attach the spring hook link up to the frame.

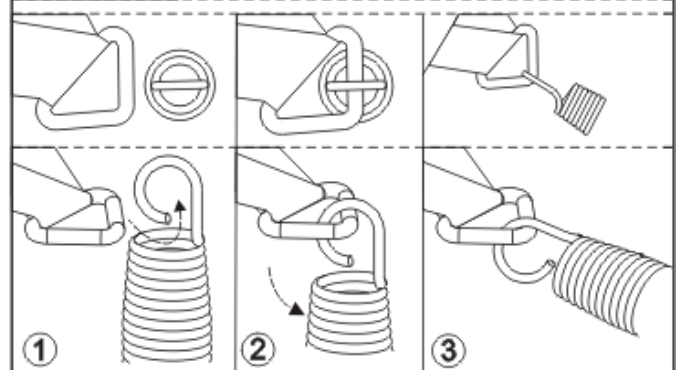
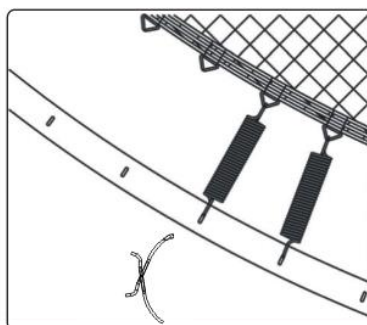
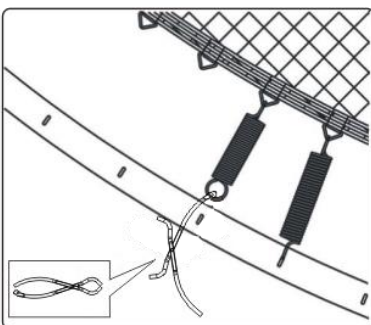
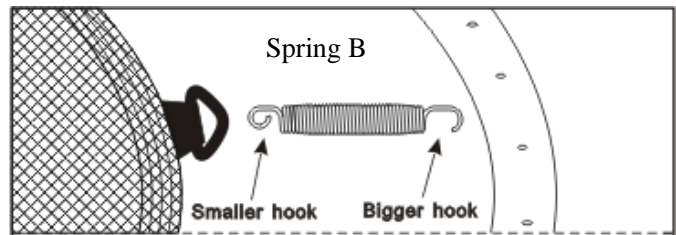
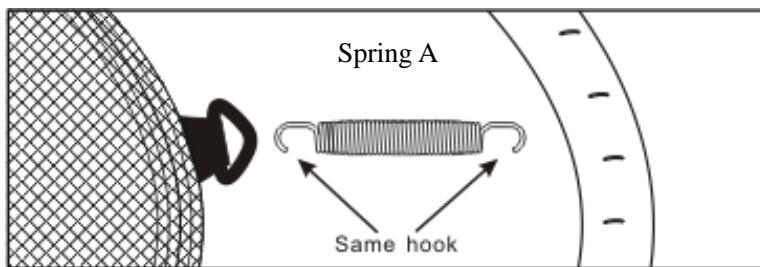

Be careful where you place your hands etc. during spring assembly as connector points can pinch!

C. The following figures tell you how to connect the springs most easily and tighten the trampoline mat as steady as possible.

D. Choose a connecting point on the frame of the trampoline. Use the clock as help and choose the point that points 12 o'clock. Position the spring on the edge of jumping mat. Attach tool and link up to the spring hook with hook end of the tool. Pull the tool and attach the spring hook link up to the frame. Repeat this at the 6 o'clock point. Assemble in the same way the first 4 springs at 12,6,3 and 9 o'clock.

E. Repeat (D) to attach the remaining springs in the same way. Take notice that the tightening of the trampoline mat should be shared equally. Therefore always attach two springs across. This is a very important. You will not be able to attach all springs because the tightening of the trampoline mat will increase with the numbers of attached springs.

Finally after assembly, the space between all springs should be equal.

Finally after assembly, the space between all springs should be equal.

F. If you notice that you have skipped a hole and V Ring connection, recount and remove or attach any springs required to maintaining the count of springs

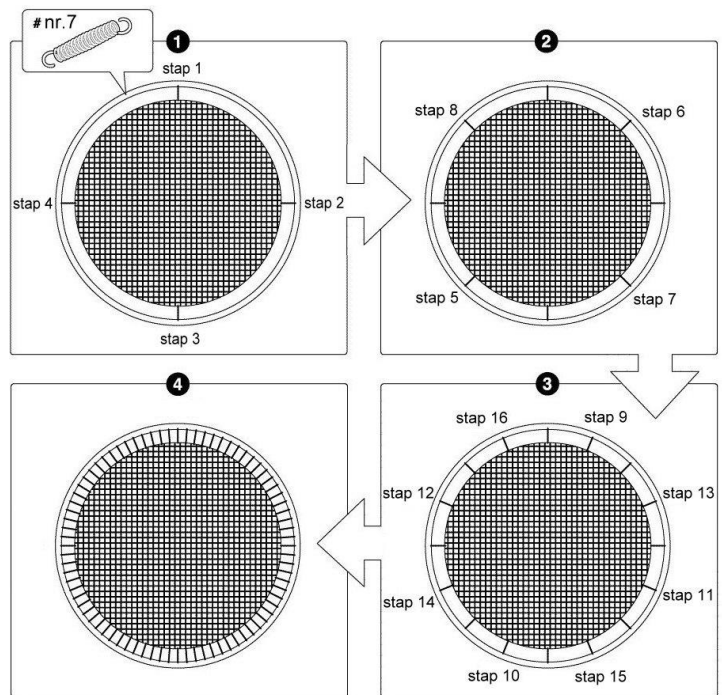

STEP 5-Frame Pad Assembly

A. Lay the Frame Pad(2)over the trampoline so that the springs and the steel frame is covered.

Ensure that the Frame Pad covers all metal parts.

B. Tie the strap located at the under side of the frame pad to the frame.

C. Select your Pad model.

Model I .

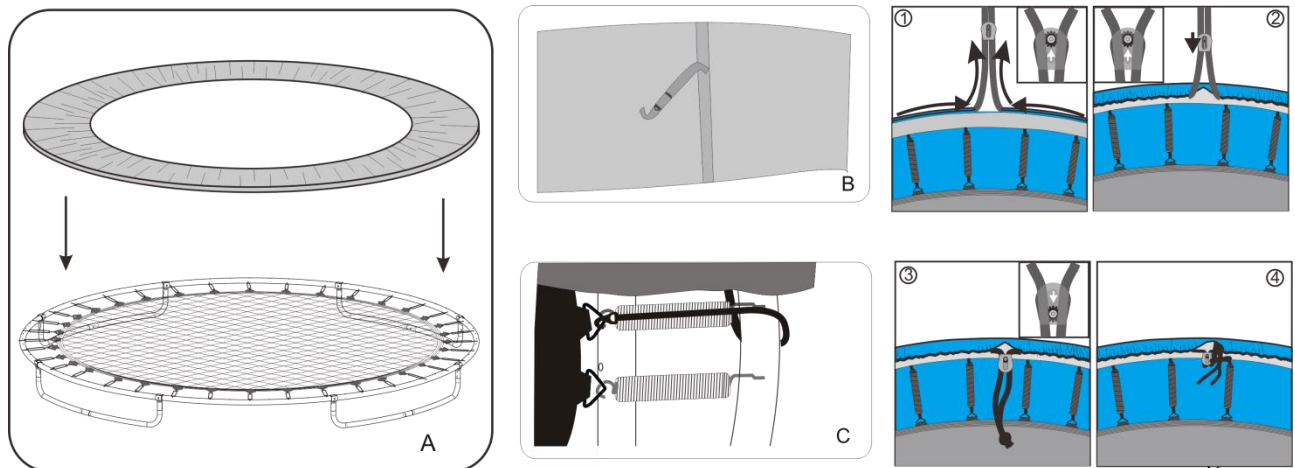

Model II.

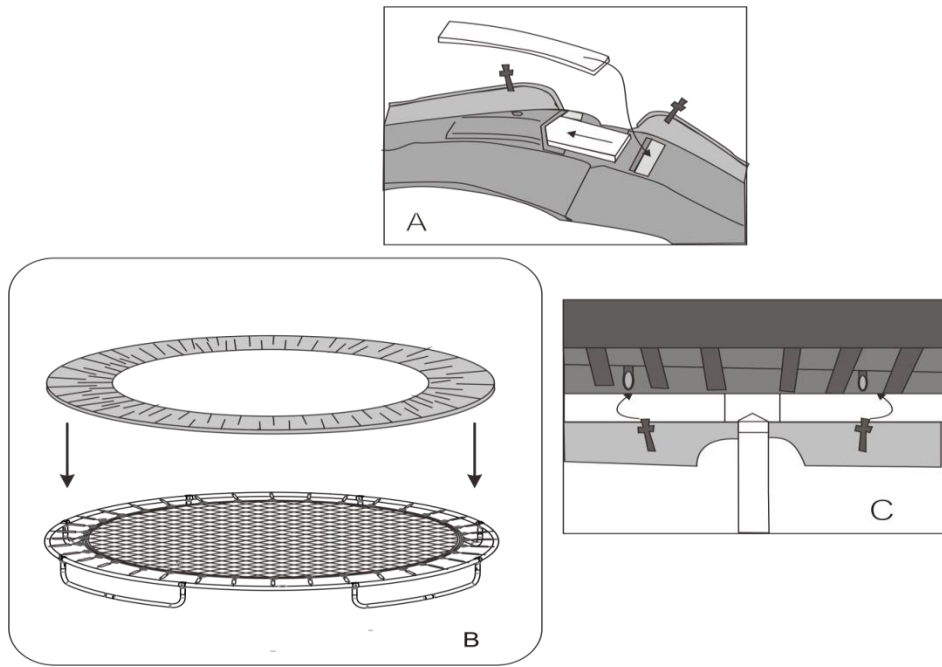

Model III.

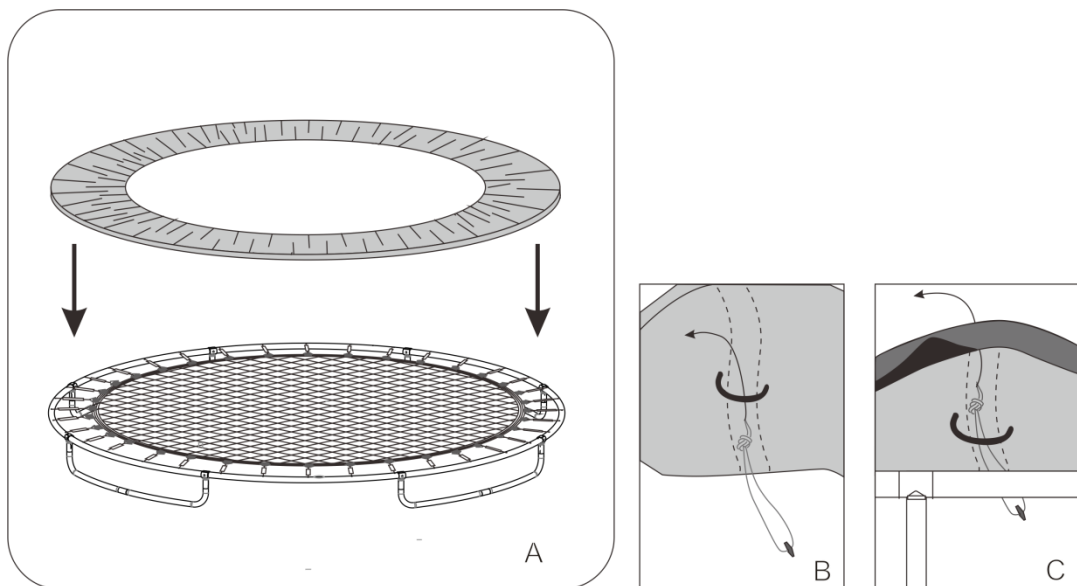

Model IV.

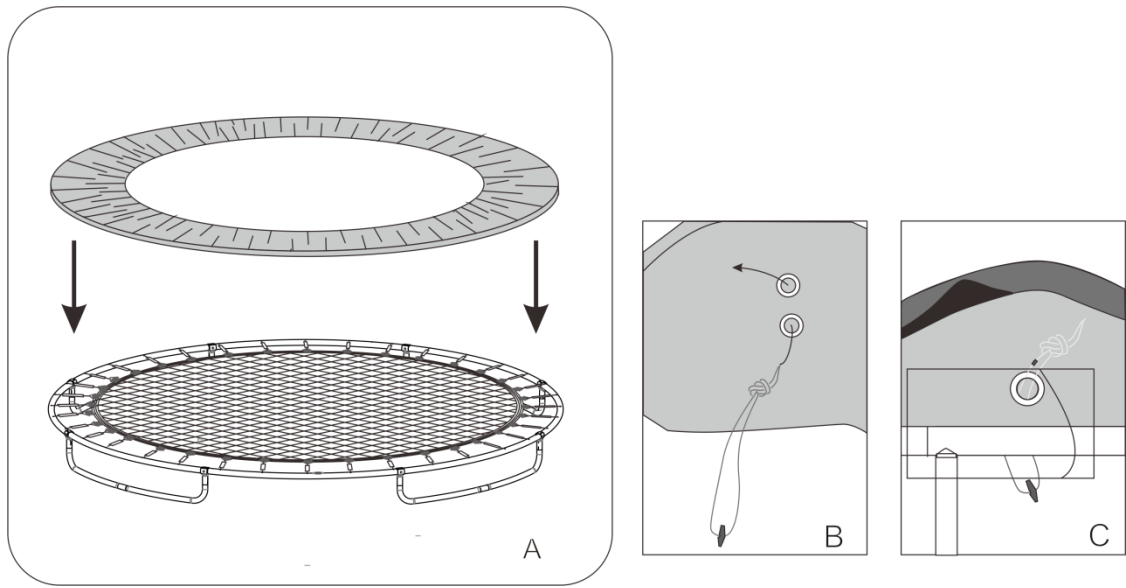

STEP 6-Fixed The Inground Trampoline

- 1.Fixed the measuring tool(attached) on the ground as Figure ①, and draw a circle of size A
- 2.Dig a hole and make sure the depth must at least match the length B as shown in Figure ②
- 3. Make the Inground trampoline cover the hole which is just under the jumping mat as Figure ③

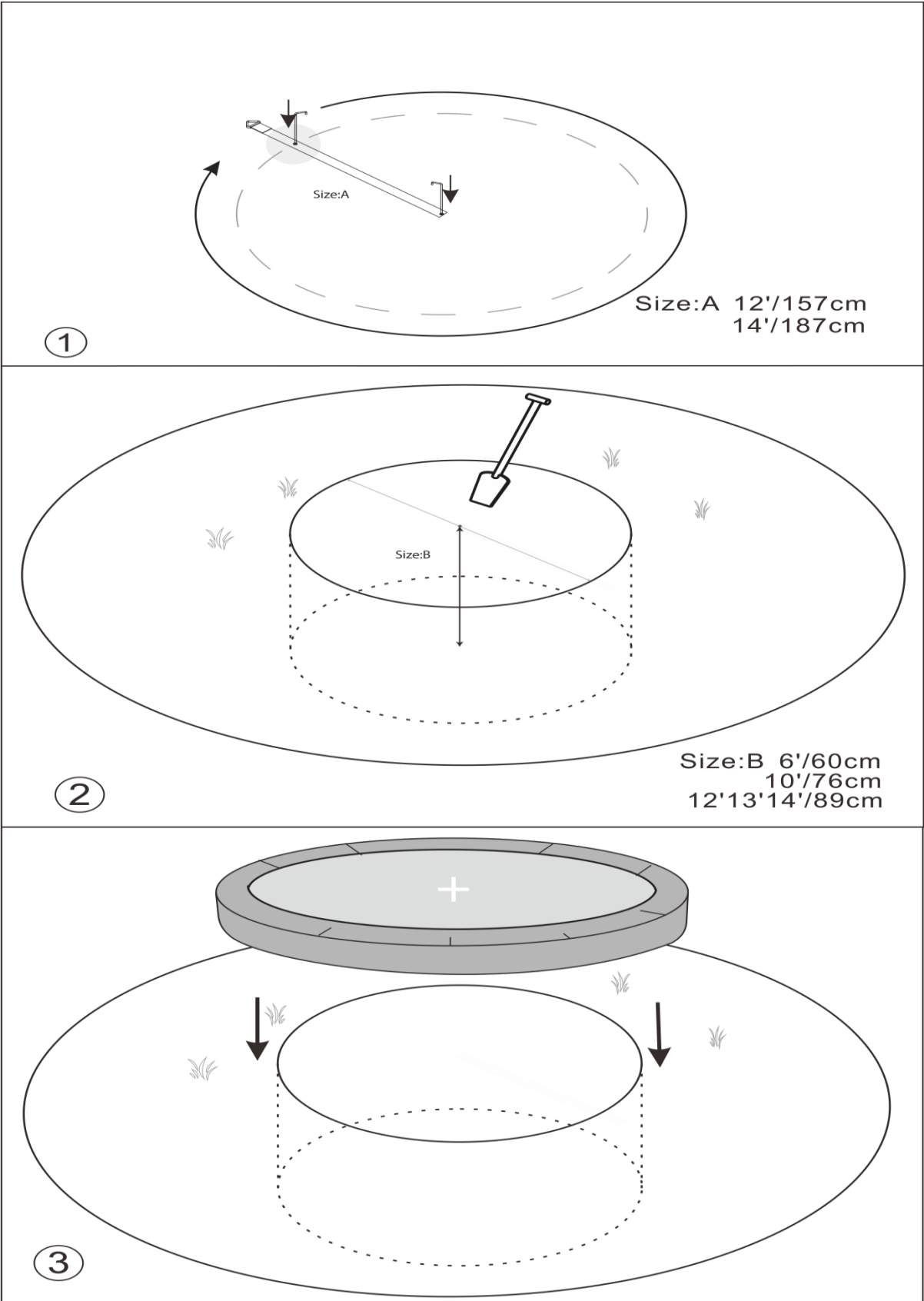

CARE AND MAINTENANCE

- **GENERAL** Your trampoline is designed to stand outside all year round and generally requires very little maintenance. However, a little care and forethought can add years to your trampoline's life. Remember that the bed (mat) and frame pads are made of synthetic materials and are easily damaged by cigarette ends, fireworks and bonfire debris.
- **FRAME** Do not sit or stand on the frame or the frame pads while the trampoline is in use as this restricts the frame's natural reflex action. Oil or petroleum jelly applied where the springs hook into the frame will reduce squeaking and frame hole wear. If surface rust appears it should be removed with either a wire brush or coarse sandpaper, and the area treated with a non-toxic paint.
- **FRAME PADS** Frame pads are there to protect the user from any fall or landing on the springs and frame. On no account should people be permitted to sit or stand on them when the trampoline is in use. You should also make sure that smaller users do not use the inside edges of the pads as a "handle" when getting up on to the trampoline.
- **THE MAT** The mat (bed) will, over the years, be gradually weakened by the effects of ultra violet radiation. Therefore, the more it can be protected from direct sunlight the longer it will last. A little mould or mildew should not harm the mat. Do make sure that shoes are removed before bouncing and ensure that any other sharp objects such as belt buckles, brooches and jewellery are removed too.
- **THE SPRINGS** Do not stand on the springs whilst the trampoline is in use. Try not to bounce on to the springs. They are not designed for this sort of stress and can become stretched, misshapen and weakened. If you find you have any stretched springs, it is important to replace them as soon as possible to avoid damage to the trampoline mat and avoid overloading and therefore damaging the remaining good springs.

This trampoline was designed and manufactured with quality materials and craftsmanship. With proper care and maintenance, it will provide all jumpers with years of exercise, fun, and enjoyment. Please follow the guide lines below:

This trampoline is designed to withstand a specific weight and usage. Ensure only one person uses the trampoline at any one time. Persons over 222 pounds (100kgs) should not use the trampoline. Jumpers should wear socks, gymnastics shoes, or be barefoot when using the trampoline. Street shoes or tennis shoes should NOT be worn while using the trampoline. To limit damage do not allow pets onto the mat. Jumpers should remove all sharp objects from their person prior to using the trampoline. All sharp or pointed objects should be kept off the trampoline mat at all times.

Always inspect the trampoline before each use for worn, damaged or missing parts. Please be aware of:

- Punctures, holes, or tears in the trampoline mat
- Sagging trampoline mat
- Loose stitching or any kind of deterioration of the mat
- Bent or broken frame parts, such as the legs
- Broken, missing, or damaged springs

-
- Damaged, missing, or insecurely attached frame pad
 - Protrusions of any types (especially sharp types) on the frame, springs, or mat
 - No modification should be carried out to the trampoline or any of its components. Any modification could lead to damage to the product or to personal injury.

IF YOU FIND ANY OF THE PREVIOUS CONDITIONS, OR ANYTHING ELSE THAT YOU FEEL COULD CAUSE HARM TO ANY USER, THE TRAMPOLINE SHOULD BE DISASSEMBLED OR SECURED FROM USE UNTIL THE CONDITION(S) HAS BEEN RECTIFIED.

WINDY CONDITIONS

In severe wind conditions, the trampoline can be blown about. If you expect windy weather conditions, the trampoline should be moved to a sheltered area or disassembled. To ensure security in normal weather conditions, at least three (3) tie downs should be used. Secure the trampoline frame to the ground. It is insufficient to secure only the legs of the trampoline to the ground as they can pull out the frame sockets.

MOVING THE TRAMPOLINE

When moving the trampoline, you will require the assistance of another adult. All connector points should be wrapped securely with weather resistant tape, such as duct tape. This will keep the frame intact during the move and prevent the connector points from dislocating and separating. When moving, lift the trampoline slightly off the ground and keep it horizontal to the ground. For any type of other move, you should disassemble the trampoline. After any move please conduct a full safety inspection.

HOW TO DISASSEMBLE THE T-SECTION

REMARKS (Only disassemble by adult.)

If you want to disassemble the trampoline, some parts maybe need to the rubber mallet (not supplied) help.

1. Maybe the leg tubes (#6) with T-section (#4) very tight, not easy disassemble. Please use the rubber mallet hit the top rail (#3). So, you can easy disassemble this part.

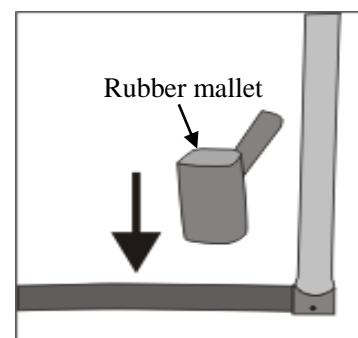

2. When you disassemble, please don't disassemble the T-section (#4) and the top rail (#3), you can keep it as it is. When you next assemble the trampoline, it will be easier and save time.

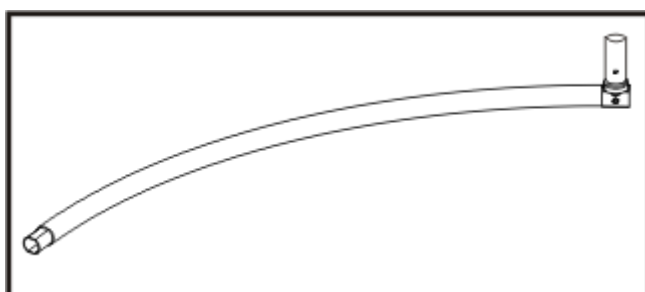

Optional trampoline accessories are available for you please contact your distributor



Trampoline Enclosures
Safety equipment



Trampoline Ladder
A ladder to help mounting and dismounting.



Atmosphere Trampoline
Kid is with more fun and safer on the trampoline.



Trampoline Tents
A fun accessory for your family. It is inadvisable to jump when the Trampoline tent is installed.



Trampoline Fix Kit
Secures trampoline during windy weather.

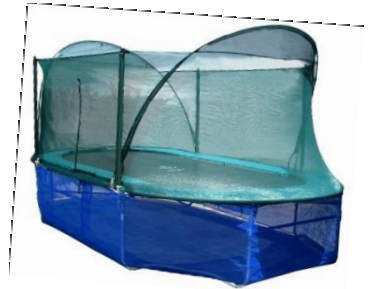

Oval Trampoline
New design Trampoline.



Trampoline PVC Weather Covers
A cover to keep leaves and other debris off the surface. Also minimizes damage by UV, rain and snow.



Trampoline" shoe/tidy " Bag
Store shoes, clothes, phones, bottles and wrist watches etc.



Bounce Board
It is very fun accessory for trampoline



TrampolinePE Weather Covers
A cover to keep leaves and other debris off the surface.



Trampoline Safety Skirt
It prevents children and pets from running under the trampoline whilst others are jumping. It can also be used to store shoes, clothes and other small items.